



XC968-EV

ELECTRIC WHEEL LOADER



Operating Weight 22730kg

Bucket Capacity 3.5m³

Rated Power 320kW



SOLID TO SUCCEED

Equipment Store Sweden AB

Långgatan 2, 827 31, LJUSDAL

Email : info@equipmentstore.se

Telefon: 0651 - 564 500



WWW.XCMGGLOBAL.COM
XCMG OFFICIAL WEBSITE



MAIN SPECIFICATIONS

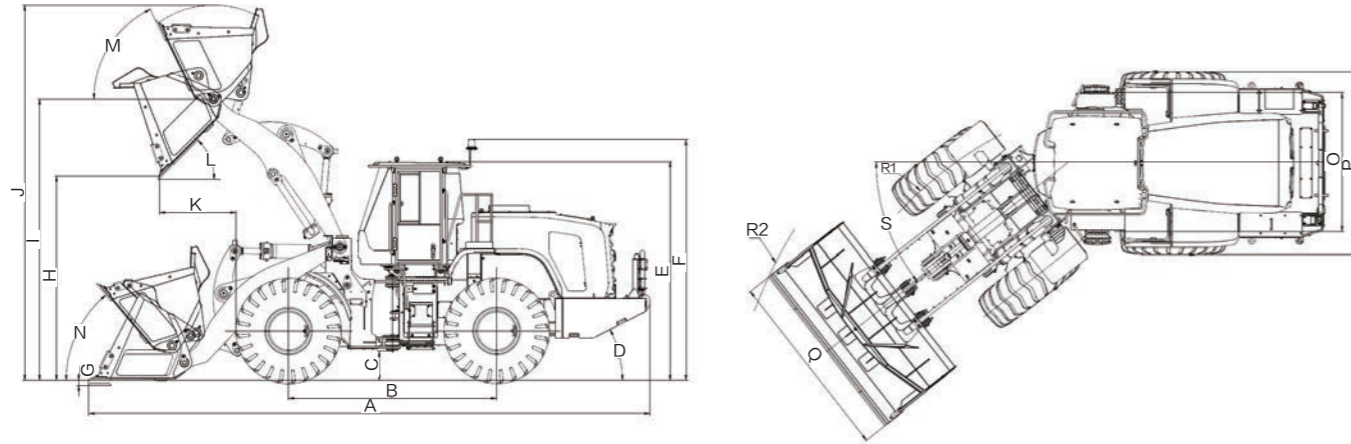

	Dimension and Specification	Parameter
A	Overall length	9130 mm
B	Wheelbase	3450 mm
C	Min. ground clearance	425 mm
D	Departure angle	27°
E	Height: ground to cab	3565 mm
F	Height: ground to beacon	3930 mm
G	Digging depth	80 mm
H	Dumping height	3340 mm
I	Height to hinge pin, fully raised	4450 mm
J	Max. lifting height	5910 mm
K	Dumping reach	1185 mm
L	Dumping angle	45°
M	Rollback angle at full lift	63°
N	Rollback angle (transfer)	43°
O	Wheel track	2255 mm
P	Width over tyres	2850 mm
Q	Bucket width	2996 mm
R1	Turning radius: tyre centerline	6160 mm
R2	Turning radius: over bucket	7050 mm
S	Steering angle	38°

• The technology of XCMG wheel loaders is subject to constant improvement and upgrading. In case the specifications or detailed appearance contained in this brochure differ from actual products, the latter shall prevail.

• XCMG reserves the right of final interpretation for the above. Our products may be modified without prior notice to users.

Overall Parameter

Type	Parameter	
Operating Weight	22730 Kg	
Bucket Capacity	3.5 m ³	
Rated Load	6000 kg	
Max. Breakout Force	160 kN	
Tipping Load	Straight	15435 kg
	Fully articulated	13721 kg

Motor & Battery

Max. Rated Output Power	320 kW
Max. Rated Output Torque (Travel)	2000 N·m
Max. Output Torque (Travel)	6400 N·m
Battery Type	LFP
Battery Voltage	618 V
Battery Capacity	423 kWh
Electrical System Voltage (Low)	24 V
Low Voltage Battery Capacity	240 Ah
Charging Time	240 kW-90 min (approximately)
	320 kW-75 min (approximately)

Hydraulic Working System

Type	Constant pressure hydraulic system
Pump	Internal gear pump
Rated Flow	380 L/min
Control Valve	Third function multiway valve
System Pressure	20.5 MPa
Operating Hydraulic Circuit	Lifting circuit for lifting, holding, lowering and staying movable status of the boom. Tipping cylinder circuit for returning, holding and tipping the bucket.
Total Circle Time	≤ 11 s

Axle

Type	Four-wheel drive
Front Axle	Fixed
Rear Axle	Oscillating frame type/with 10.5° oscillating angle to each side
Reduction Gear	Planetary final drive
Differential	Conventional differential